

SR31/43/81 Robot Series Servo Specification

MODEL	SIZE (mm)								WEIGHT		6.0V			7.4V			STRUCTURE	
	A	B	C	D	E	F	G	H	g	oz	SPEED	TORQUE		SPEED	TORQUE		gear	bearing
											sec/60°	kg·cm	oz·in	sec/60°	kg·cm	oz·in		
SR310	31.3	16.3	28.5	37.5	7.5	4.1	4.9	3.2	19.0	0.67	0.14	2.5	34.8	-	-	-	plastic gear	single bearing
SR311	31.3	16.3	28.5	37.5	7.5	4.1	4.9	3.2	26.0	0.92	0.14	3.0	41.7	-	-	-	metal gear	double ball bearing
SR430	42.0	20.5	39.5	49.0	10.0	7.0	5.7	4.75	44	1.55	0.18	4.2	58.4	0.16	5.3	73.6	plastic gear	double ball bearing
SR431	42.0	20.5	39.5	49.0	10.0	7.0	5.7	4.75	62	2.18	0.20	12.2	169.7	0.18	14.5	201.4	metal gear	double ball bearing
SR810	60.5	30.7	60.0	69.0	16.9	9.2	10.0	6.80	123	4.34	0.21	20	278.2	-	-	-	plastic gear	double ball bearing
SR811	60.5	30.7	60.0	69.0	16.9	9.2	10.0	6.80	164	5.75	0.21	33	459.1	-	-	-	mixed gear	double ball bearing

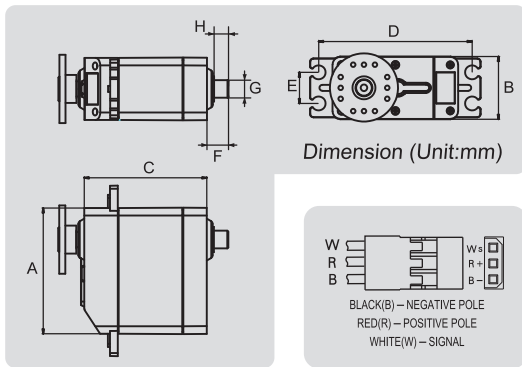

- ▲ This series servo is the extension type of generalized model product of SPRINGRC, In low-recover of servo, it is added the accessory shaft for Robot servo, and adopts exclusive MCU circuit control.
- ▲ This series servo is controlled via analog signal(PWM), the range of signal impulse:0.5ms~2.5ms.
- ▲ Rotation range : 0°~180°,PWM width: 0.5ms~2.5ms, rotation from 0°to 180°
- ▲ Please choose the correct model for you application.Caution: mechanism and electronic device will be damaged by overload torque and inadequate safety factor.
- ▲ Please keep the servo environment clean and away from dust, aggressive gas and humid air.
- ▲ Without further notification when some parameters slightly amend for improving quality and performance.